

323

322

Regenwasser
Rückhaltefläche
2038,75m²

Garage A wird
extra angeboten

Garage A wird
extra angeboten

Garage A wird
extra angeboten

Carports/ Garagen 597,60 m²

A 73 74 75 76 79 80 86 81 90 52 22 57 39 40 68 41 A 42 17 82 72 64 A 54 45 56 46 47 48

101,26m²
361,55
TZ

Spielplatz
719,07m²

302,37m²

290,84m²

121,56m²

240,67m²

240,62m²

240,83m²

240,43m²

240,76m²

240,42m²

240,58m²

240,51m²

240,53m²

240,45m²

240,47m²

240,60m²

258,42m²

287,60m²

49,42m²

152,52m²

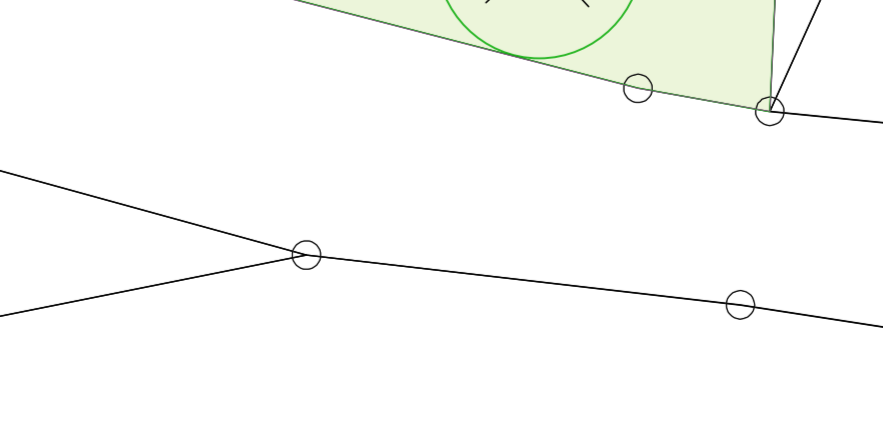
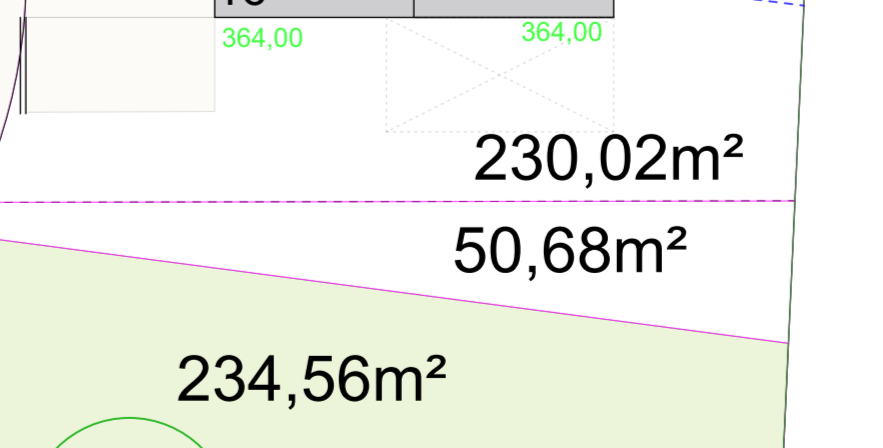
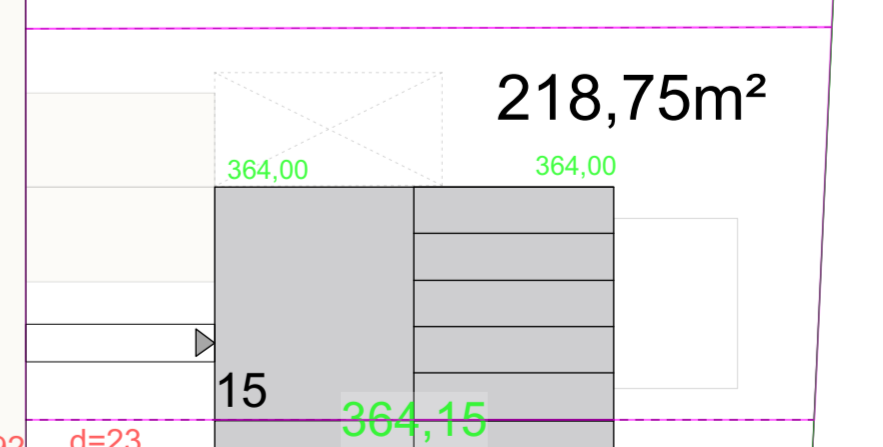
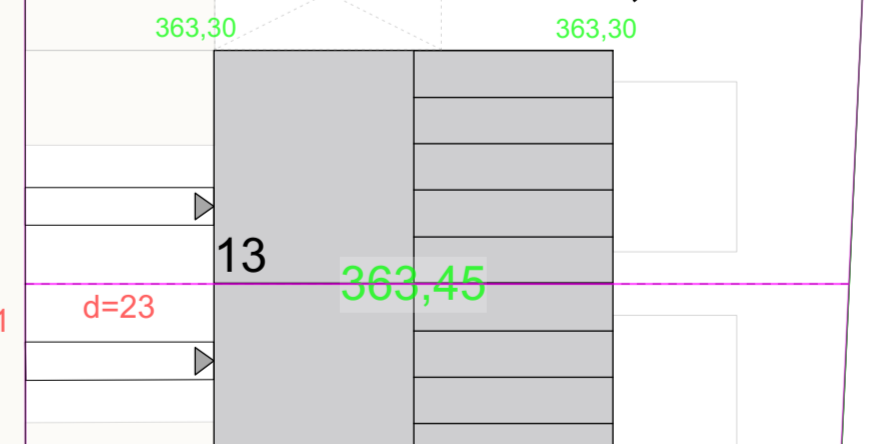
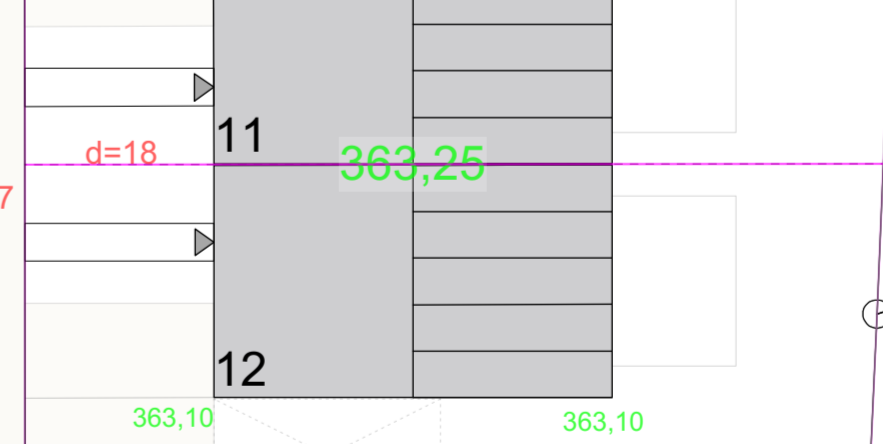
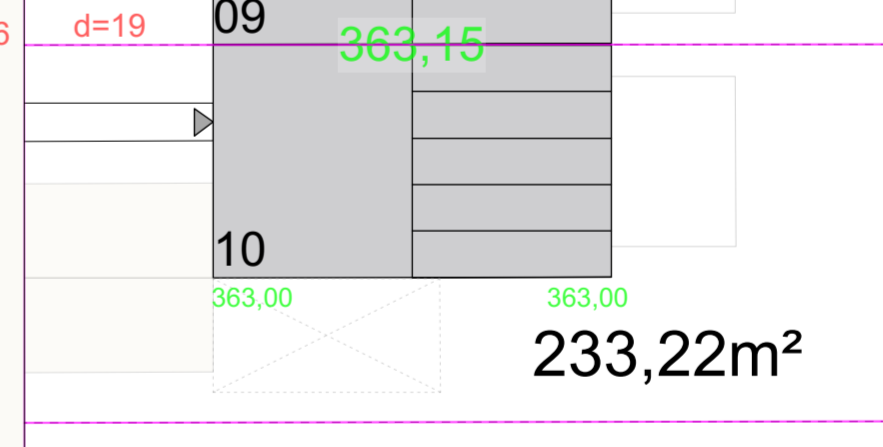
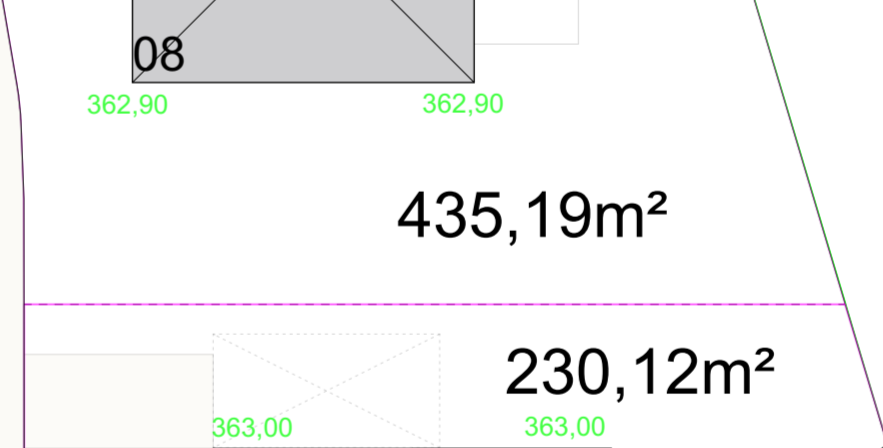
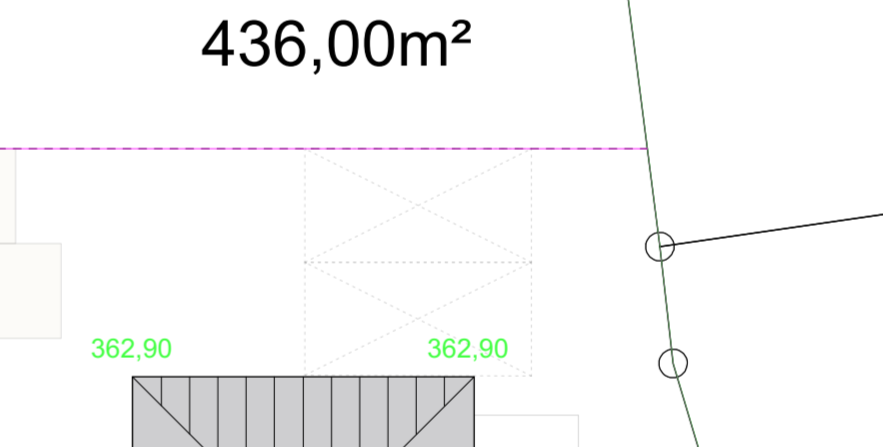
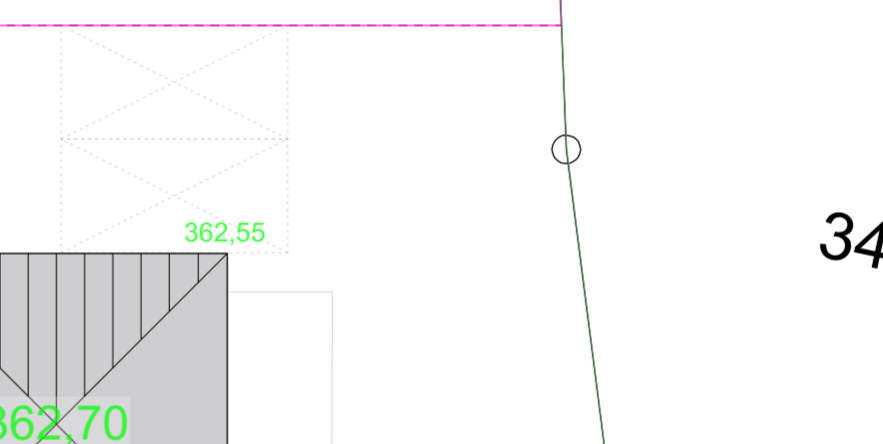
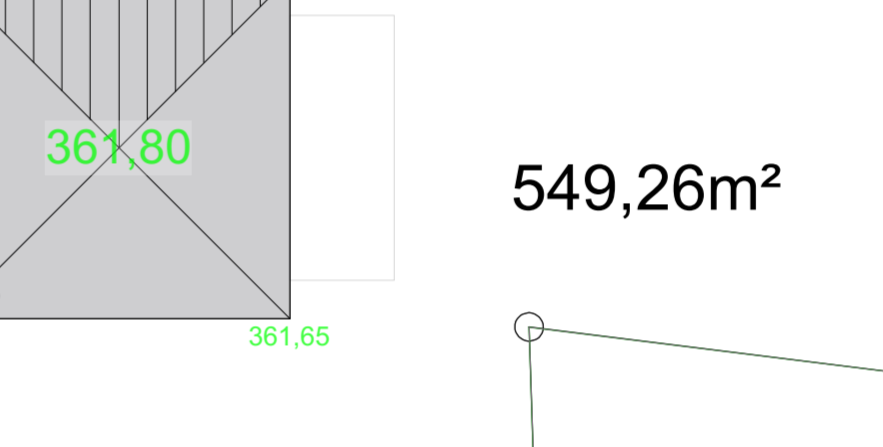
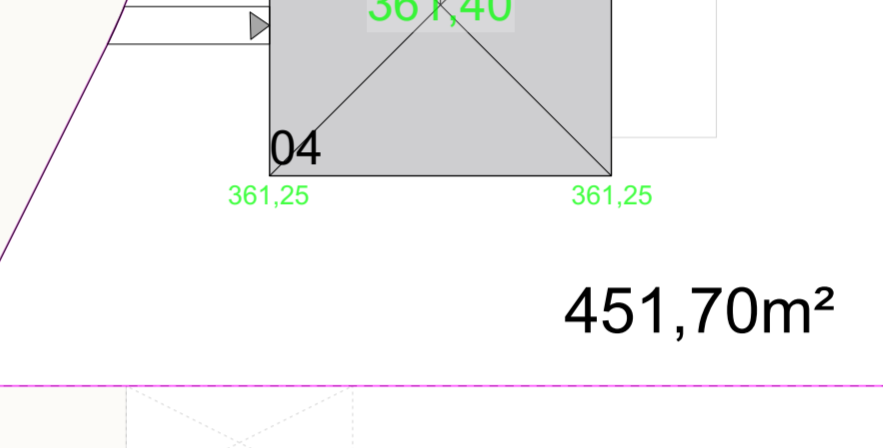
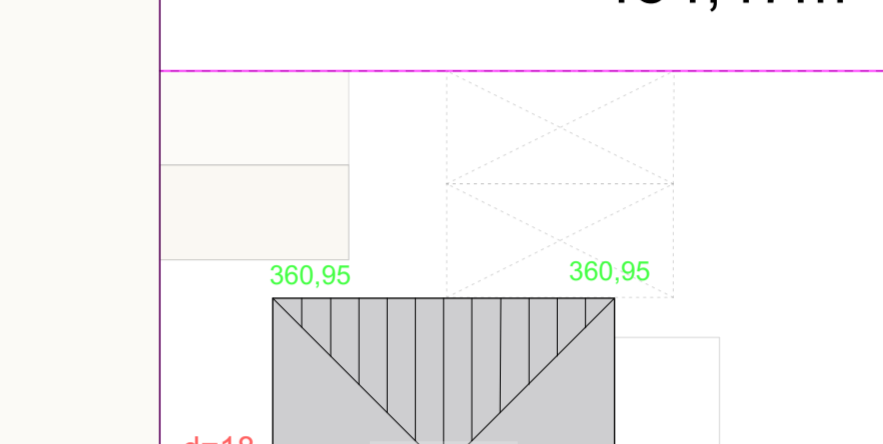
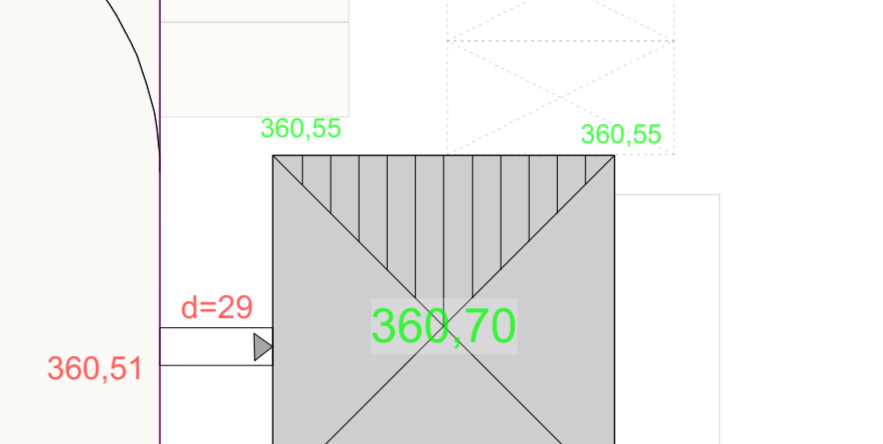
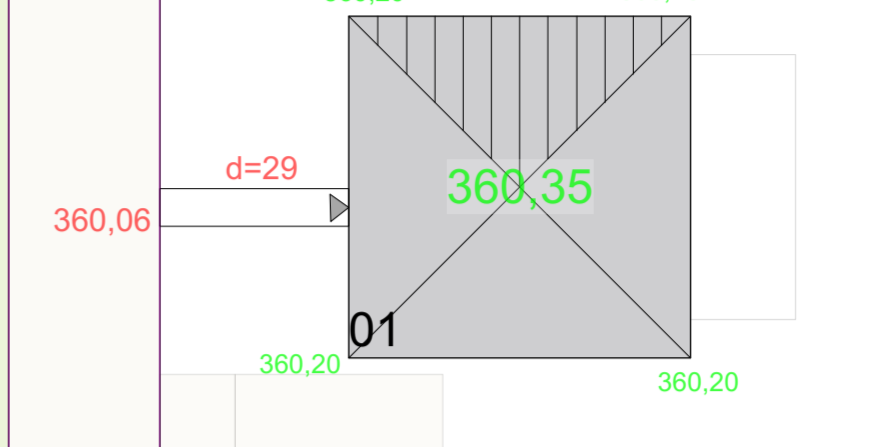
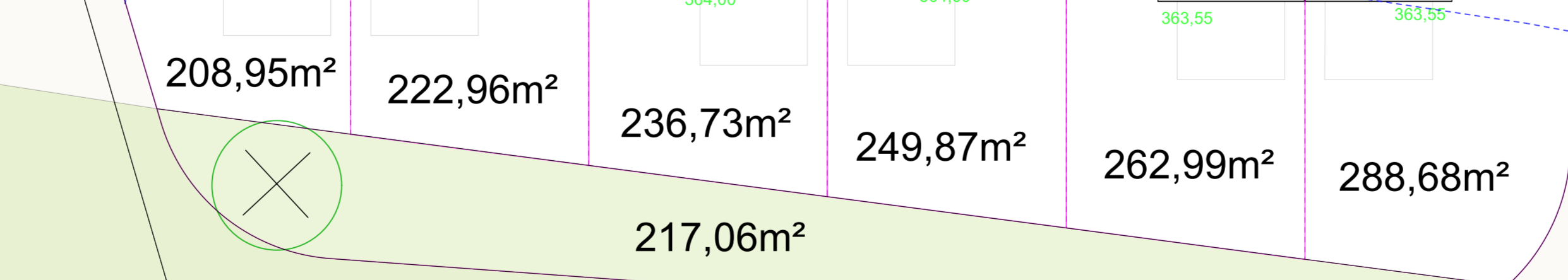
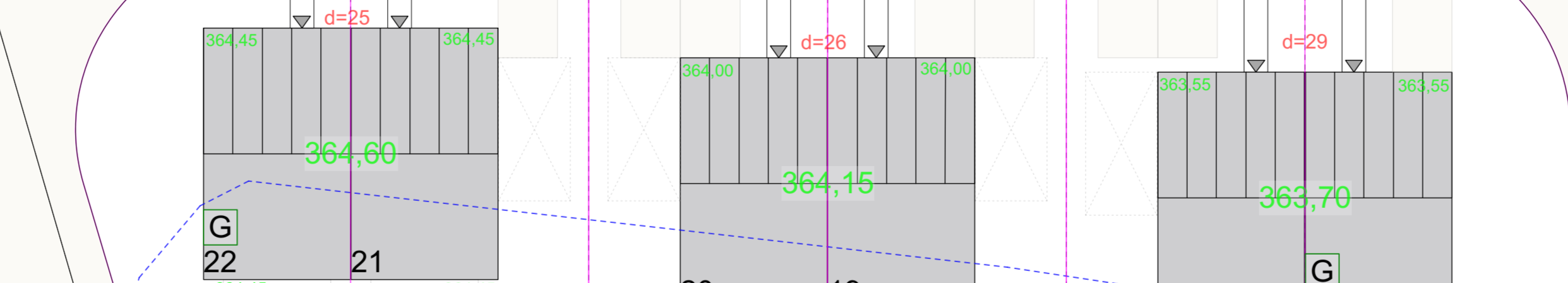
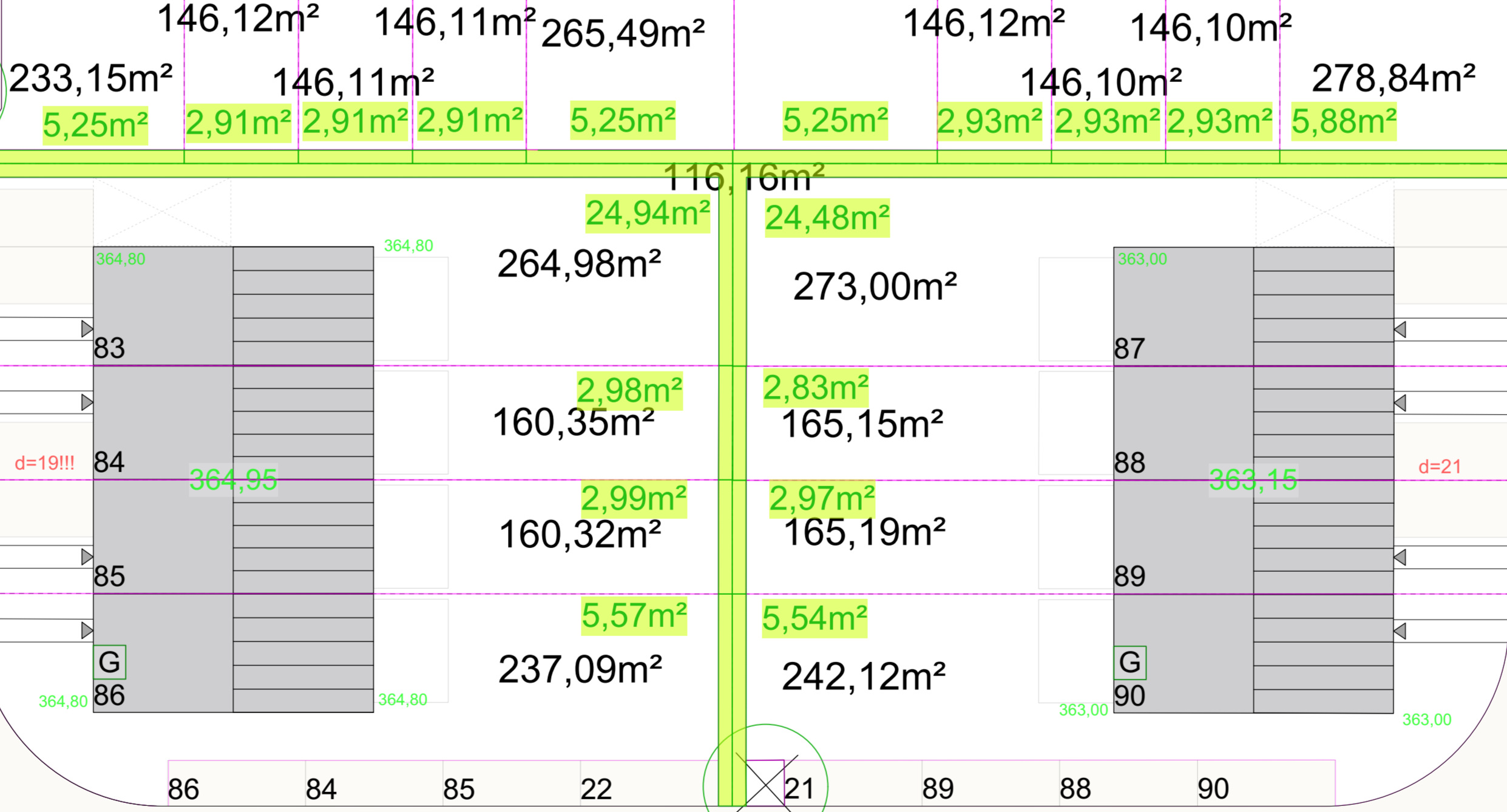
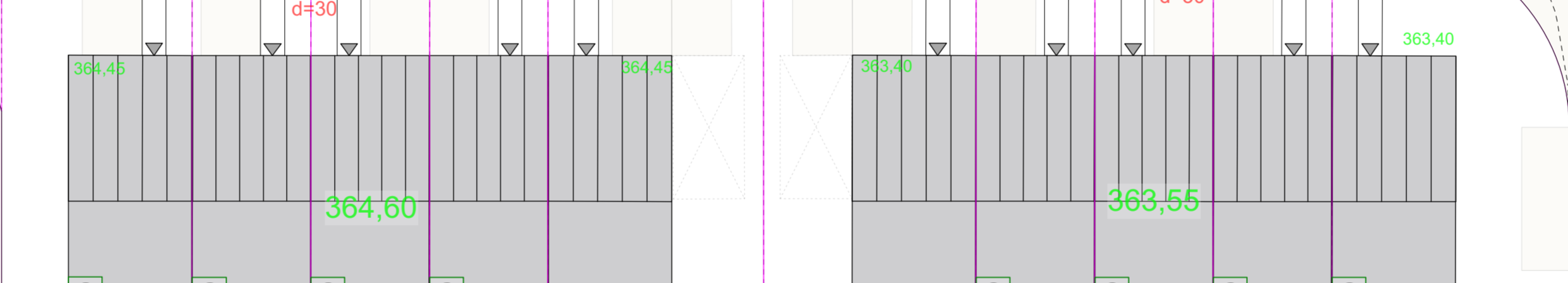
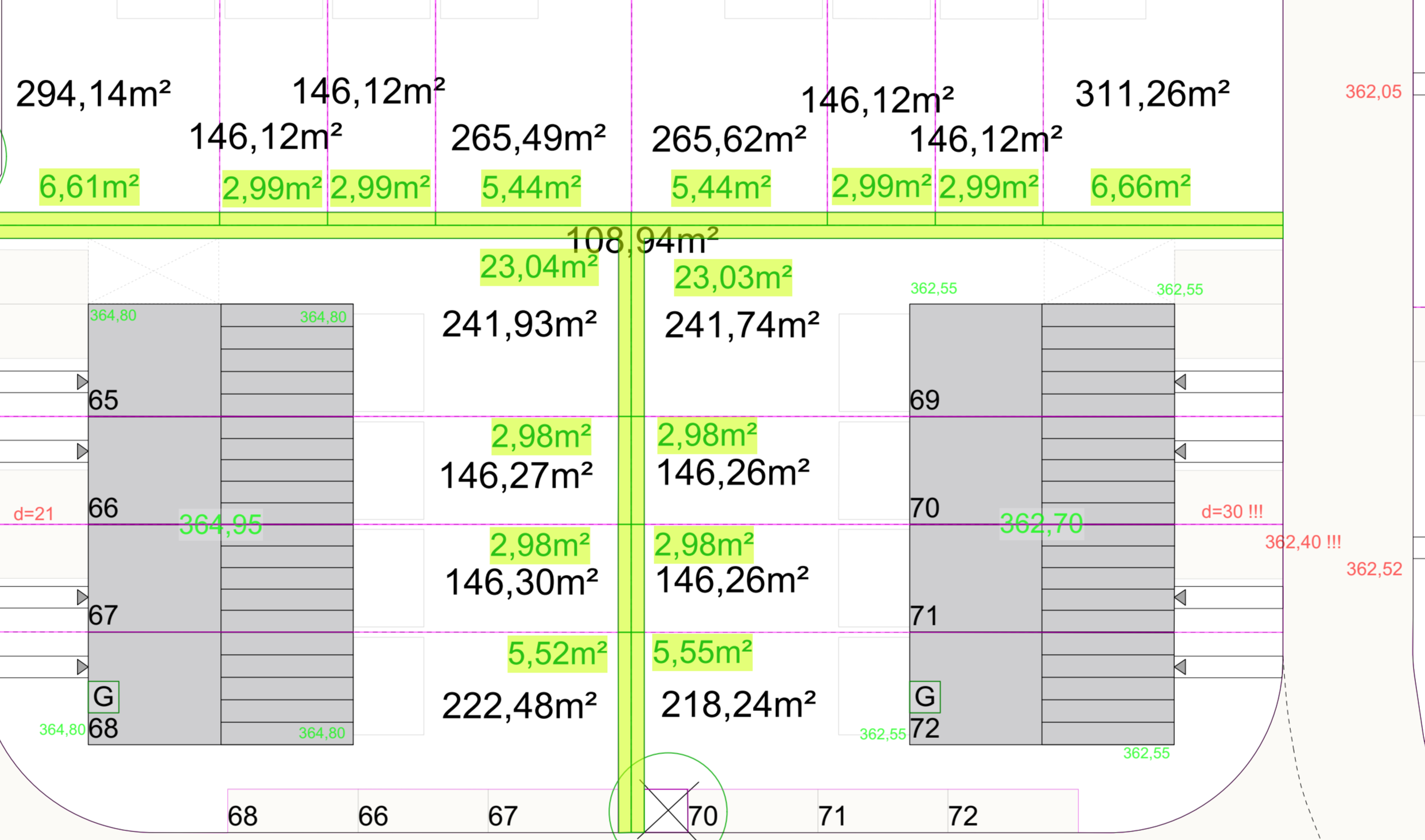
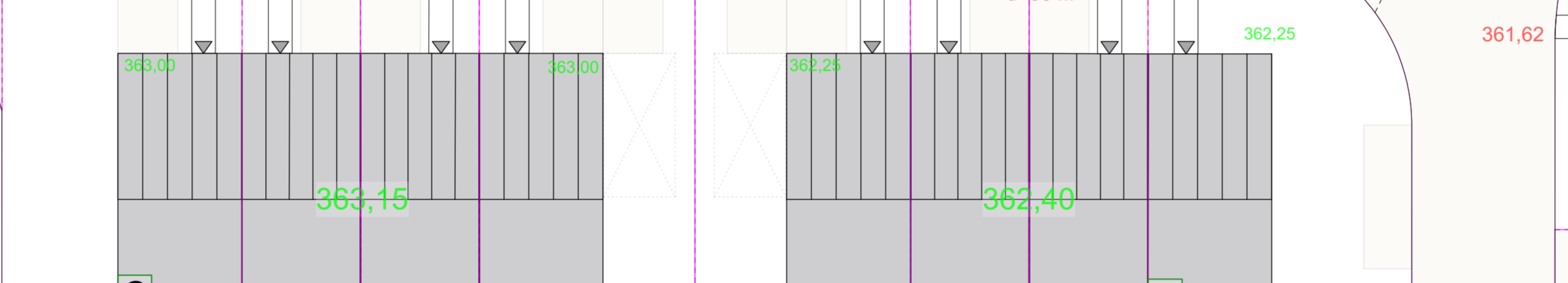
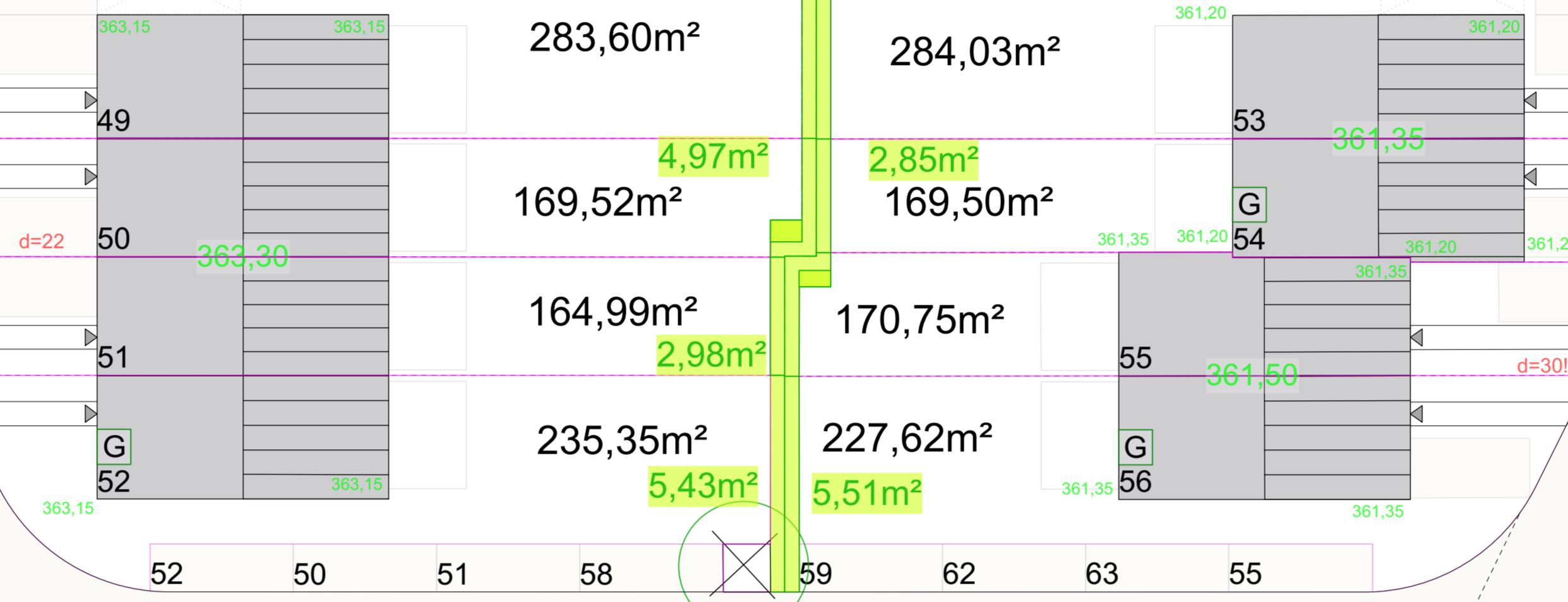
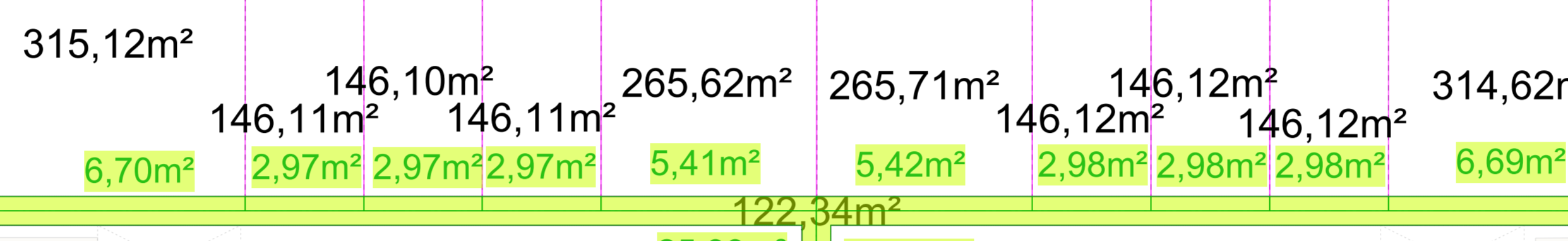
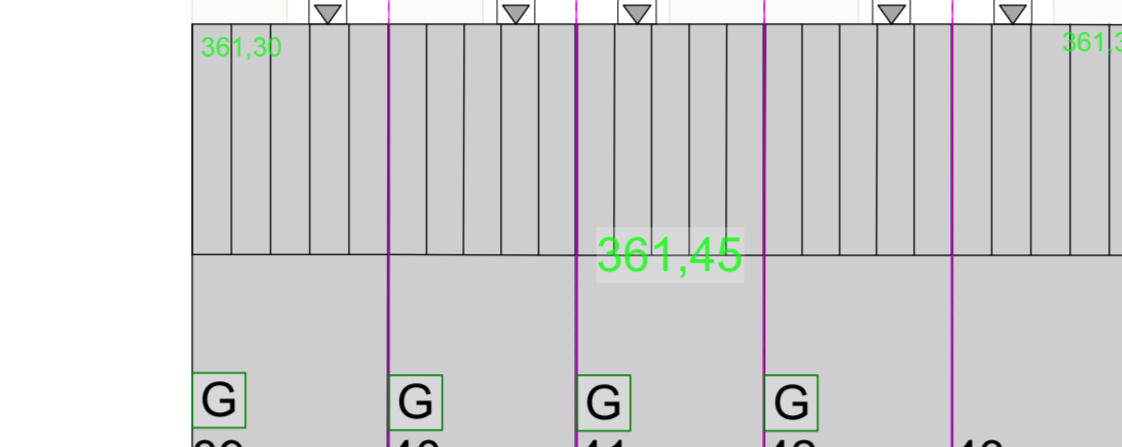
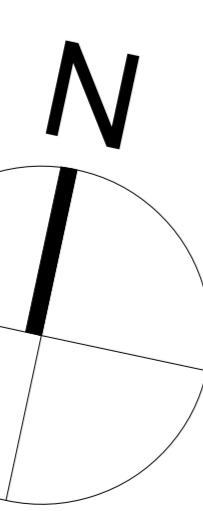

334/1

43

454,47m²

437,28m²

451,70m²

549,26m²

344

344/6

344/22

437,81m²

436,00m²

435,19m²

230,12m²

233,22m²

229,47m²

224,66m²

220,59m²

240,51m²

215,29m²

218,75m²

230,02m²

50,68m²

234,56m²

217,06m²

249,87m²

262,99m²

288,68m²

217,06m²

217,06m²

217,06m²

217,06m²

217,06m²

217,06m²

217,06m²

VORABZUG
Legend: WE (Wohnheiten), TZ (Tücheln/Zentraln), A (Abstellfläche), St (Stellplatz Öffentlich), G (Garage/Sonderwunsch), M (Müllweg), S (Straße), H (Höhen/Bestand), V (Vorneisen), HO (Höher), P (Pflanzzone/Bauminterior), B (+100%/-100%), I (+10/-10 cm), C (Gelände), B (Büschung/Höhe), L (Länge), T (Tropfen/Garten), S (Stufe H=15 cm).
Project: Neubau von 90 Wohneinheiten (DHN, REH & EPH) for RTH+P+K, 301, 303, 309, 340/1, 341, 342, 343, 344/1, 344/2, 344/6, 344/22, 344/6, 344/7, 344/8, 345/1, 345.
Architect: Wengertler MASSIVHAUS
Date: 28.04.2019
Scale: M 1:200

423